

CHAMBER		Volume (gal)
①	Sedimentation Chamber	558
②	Anaerobic Filtration Chamber	556
③	Aerobic Contact Filtration Chamber	248
④	Clarification Chamber	125
⑤	Disinfection Chamber	11
Total Volume		1,498

SPECIFICATIONS	
Anaerobic Media	PP / PE
Board Type Aerobic Media	PVC / PP / PE
Aerobic Media	PP / PE
Blower	5.3 cfm
Tank	FRP
Piping	PVC / PP / PE
Access Covers	Plastic / Cast Iron
Disinfectant (Optional)	Chlorine Tablets

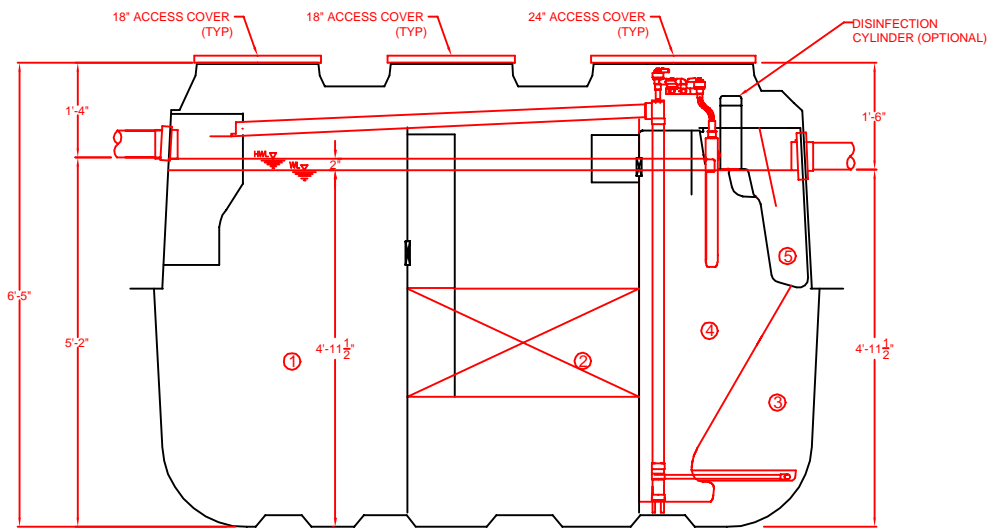

**SECTION A-A VIEW**

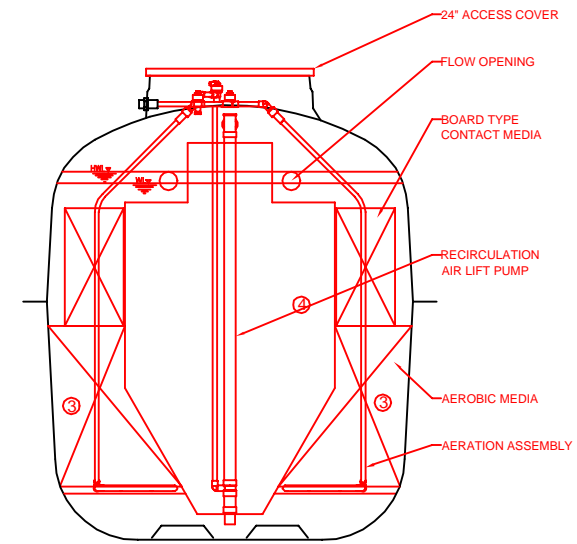

**SECTION B-B VIEW**

